

# VOLTAGE PORTALS

Provides maintenance personnel a no touch voltage verification on the outside of the cabinet



## VOLTAGE PORTAL FEATURES

- ▶ **Grace Voltage Portals** are PESDs that improve task productivity by providing qualified maintenance workers a no-touch voltage verification on the outside of grounded metallic enclosures.
- ▶ **Voltage Portals** provide the means to perform measured voltage detection from outside the cabinet through the use of a Non-Contact Voltage Detector (NCVD) Pen without the risk of being exposed to arc flash or shock hazards.
- ▶ Provides a safer and more productive method for performing LOTO, while enhancing compliance mandated by OSHA & NFPA 70E/CSA Z462.
- ▶ Enables task qualified workers to verify voltage presence on the outside of the door in highly corrosive industrial environments.

FOR MORE INFORMATION VISIT [PESD.COM](http://PESD.COM) OR CALL 1.800.280.9517



## OPERATION

**Grace PESD® Voltage Portals** allows the task qualified maintenance worker to safely and productively perform voltage verification from outside a grounded electrical enclosure. Installed on the door or flange of an electrical cabinet using a 1/2" or 30mm standard punch hole with site specific procedure labels, workers can perform a voltage test using an adequately rated CAT III/CAT IV Non-Contact Voltage detector (NCVD) Pen during mechanical lockout/tagout. The voltage portal is typically connected to the load side of the electrical disconnect by a qualified electrician.

## VOLTAGE PORTAL TECHNICAL SPECIFICATIONS

	CAT III	CAT IV
<b>COMPONENT CODE</b>	<b>R-T3</b>	<b>R-3K</b>
Voltage Type	AC	
Mounting Location	External (door mounted)	
Lead Connections	3-Phase, 3-Wire	3 Phase, 3 wire Wires not supplied
Operational Temperature Range	-20°C to +60°C	
Operational Voltage Range	1000VAC Maximum - <i>Minimum voltage sensing value vary by the type and class of NCVD pen used</i>	
Pollution Degree	2	
Chemical Resistance**	Characteristics of polycarbonate material apply	
Wiring Specifications	PVC Insulated with Nylon Jacket, 6ft, 12 AWG, 90°C @ 1000 Volts, UL-1452	No additional wiring needed. Allows Wires sizes: 18 AWG to 12 AWG
Installation	30mm pushbutton hole	
Certifications	cUL Listed (#E311256) Type 4, 4X, 12, CE	

\*\* See Voltage Portal Chemical Resistance Application Note for more details.

## LABELS

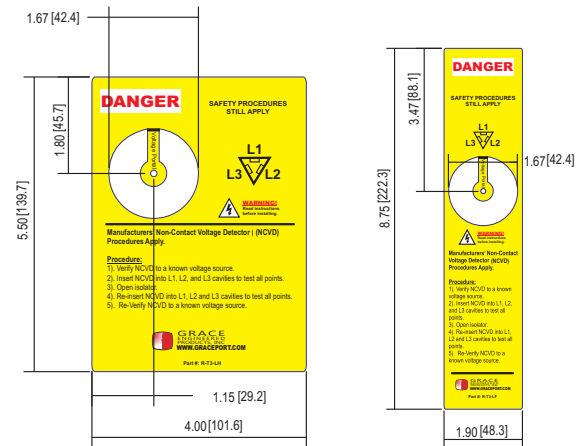

R-T3-LH Horizontal Label  
*Applies to the R-T3*

R-T3-LF Vertical Label  
*Applies to the R-T3*

**Custom label variations available upon request. Please call 1-800-280-9517 for more information.**

## COMBINATION UNITS

The R-T3 Voltage Portal is also sold in combination with our R-3W Series Voltage Indicators coupled together with custom labels. With our voltage indicator and portal connected to the same source, a task qualified worker can visually verify the voltage presence in addition to a measured test using a NCVD Pen.



R-T3W-LCH



R-T3W2-LCH



R-T3W-LCF



R-T3W2-LCF

## ACCESSORIES



Fluke® NCVD Pen  
**Sensing Range: 90 - 1000VAC**  
Add a "-J" to the end of the part number to also receive the NCVD Pen with your order

**FOR MORE INFORMATION VISIT [PESD.COM](http://PESD.COM) OR CALL 1.800.280.9517**

**Warning:** Verify an electrical conductor has been de-energized using an adequately rated test instrument before working on it. Follow appropriate Energy Control (Lockout/Tagout) procedures as per OSHA Subpart S.

© Grace Technologies All rights reserved. Specifications are subject to change with/without notice.

## R-T3 DETAIL

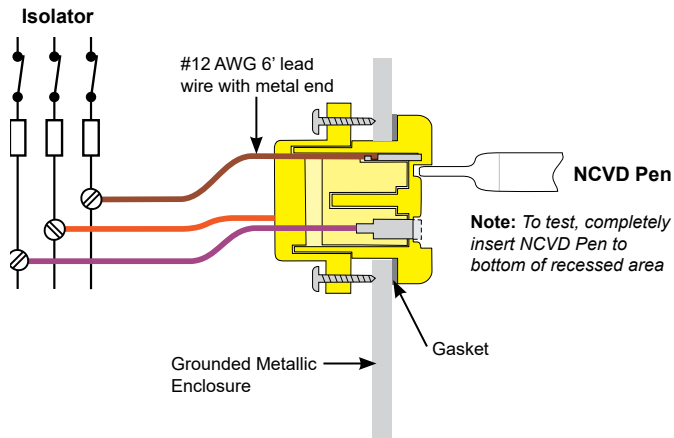
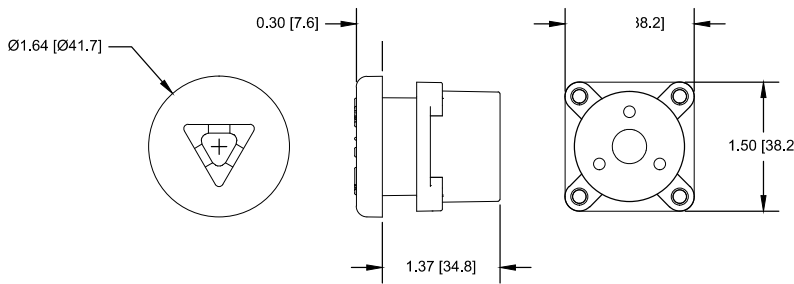

## R-T3 FEATURES

- ▶ 3 Phases combined into one unit
- ▶ Integral 6' #12 AWG lead wire
- ▶ Installs in a 30mm hole for easy installation
- ▶ Rugged polycarbonate construction for safety
- ▶ UV Outdoor rated so you can mount it in any grounded metallic enclosure
- ▶ Fits panel thicknesses up to .250"
- ▶ Screws supplied with product



## R-3K DETAIL

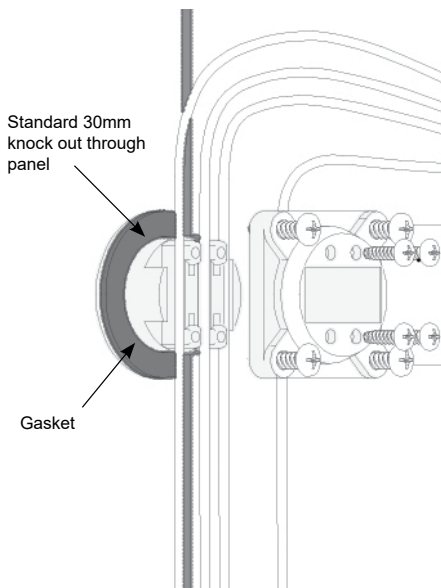

## R-3K WITH AN EXISTING VOLTAGE INDICATOR

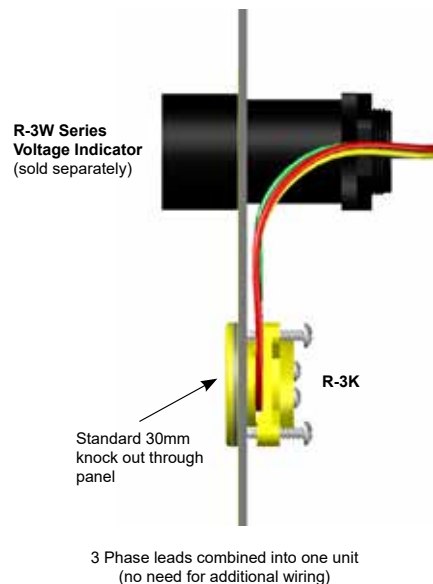

## R-3K FEATURES

- ▶ Accepts wires from 18 - 12 AWG
- ▶ Installs in a 30mm hole for easy installation
- ▶ Rugged polycarbonate construction for safety
- ▶ UV Outdoor rated so you can mount it in any grounded metallic enclosure
- ▶ Screws supplied with product

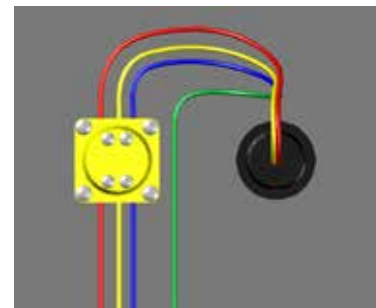

FOR MORE INFORMATION VISIT [PESD.COM](http://PESD.COM) OR CALL 1.800.280.9517

**Warning:** Verify an electrical conductor has been de-energized using an adequately rated test instrument before working on it. Follow appropriate Energy Control (Lockout/Tagout) procedures as per OSHA Subpart S.

© Grace Technologies All rights reserved. Specifications are subject to change with/without notice.



CHS Controls AB  
Tel +46 42 38 61 00, Fax +46 42 38 61 29  
chs@chscontrols.se www.chscontrols.se



RoHS CE

## FREQUENTLY ASKED QUESTIONS

**Q: How do Voltage Portal PESDs and NCVD pens assist during mechanical LOTO?**

*A: Once the Voltage Portal is properly installed, wired, and documented, a task qualified person can safely perform the measured test for presence of voltage using a NCVD pen from outside the electrical cabinet during mechanical LOTO.*

**Q: How do voltage portals enhance task productivity in mechanical LOTO?**

*A: Voltage Portals when used in conjunction with the Voltage Indicators and wired to the same source of voltage, enhances the productivity when a task qualified maintenance worker can quickly verify voltage presence using two redundant methods of visual indication and a NCVD pen at the LOTO point.*

**Q: Why should I use Voltage Portals ONLY on grounded metallic enclosures?**

*A: NCVD pens used with voltage portals rely on a capacitive coupling to ground, which makes the NCVD less versatile than a phase-to-phase/phase-to-ground voltmeter test. However, with Voltage Portals installed and the panel energized, workers can test the Voltage Portal with the NCVD to ensure it works. This means a capacitive ground connection exists and will always exist because panels do not move and workers stand in the same place when they test.*

**Q: Can I use voltage portals and NCVD pens on ungrounded systems?**

*A: No, ungrounded and isolated grounded systems may not always create a capacitive coupling to detect the voltage with a NCVD Pen.*

**Q: What is the advantage of installing a Voltage Portal in an electrical cabinet?**

*A: The ability to safely verify voltage presence for mechanical LOTO and pre-verify for electrical LOTO prior to opening an electrical panel using a Voltage Portal and NCVD pen puts an additional safety barrier between the worker and hazardous voltage.*

**Q: Can I use Voltage Portals and NCVD pens on DC voltage systems?**

*A: No, Voltage Portals and NCVD pens work only on AC voltage systems up to 1000 Volts. Voltage range and accuracy of the NCVD pen vary by manufacturer.*

**Q: Why should I use an adequately rated NCVD pen with voltage portals?**

*A: Most NCVD pens have a specific sensing range and ratings within which they are specified to operate properly. Some are designed to work on the low voltage control circuit applications, others specified for residential and industrial environments. When selecting your NCVD pen, be sure to pick the one that meets your application environment and voltage ratings. Most industrial applications use 1000 Volts, CAT IV Rated NCVD pens.*

**Q: Can I use R-3K pass-thru Voltage Portals by themselves?**

*A: R-3K voltage portals can be used to verify the voltage of any door mounted device with a 12-18 gauge wire and also with new or existing R-3W Voltage Indicators. By passing the phase leads of the door mounted device or voltage indicator through the voltage portal saves installation time as there is no need for additional wiring and connections.*

**Warning:** Verify an electrical conductor has been de-energized using an adequately rated test instrument before working on it. Follow appropriate Energy Control (Lockout/Tagout) procedures as per OSHA Subpart S.

© Grace Technologies All rights reserved. Specifications are subject to change with/without notice.



SS-VP-DS-EN 2103



CHS Controls AB  
Tel +46 42 38 61 00, Fax +46 42 38 61 29  
chs@chscontrols.se www.chscontrols.se